

Galvin Assist WF CC cleanflush WC + seat

PRODUCT CODE: 105.10.00.03



Clean Flush, Easy Care Height

- Clean Flush rimless pan design for an efficient, powerful flush
- Easy care height, pan height 425 mm.
- White vitreous china
- Quick release, soft closing seat
- S trap only
- Bottom entry plumbing, optional back entry plumbing
- 140 recommended setout
- WELS 4 star 4.5/3L water saving flush.

CISTERN	Bottom entry as standard, left and right inlet points. Optional back entry plumbing.
PAN	Close coupled with rimless pan design.
TRAPS	Suitable for S trap installations.
SEAT	Quick release, soft closing seat.
WELS	4-star rating 4.5/3 liter water saving flush. WELS license 0296.
SETOUT	140 mm recommended.
FIXING	This is a close coupled toilet suite — the cistern is fixed directly to the pan and does not require wall fixing. Pan may be bedded with cement base or using silicone sealant.

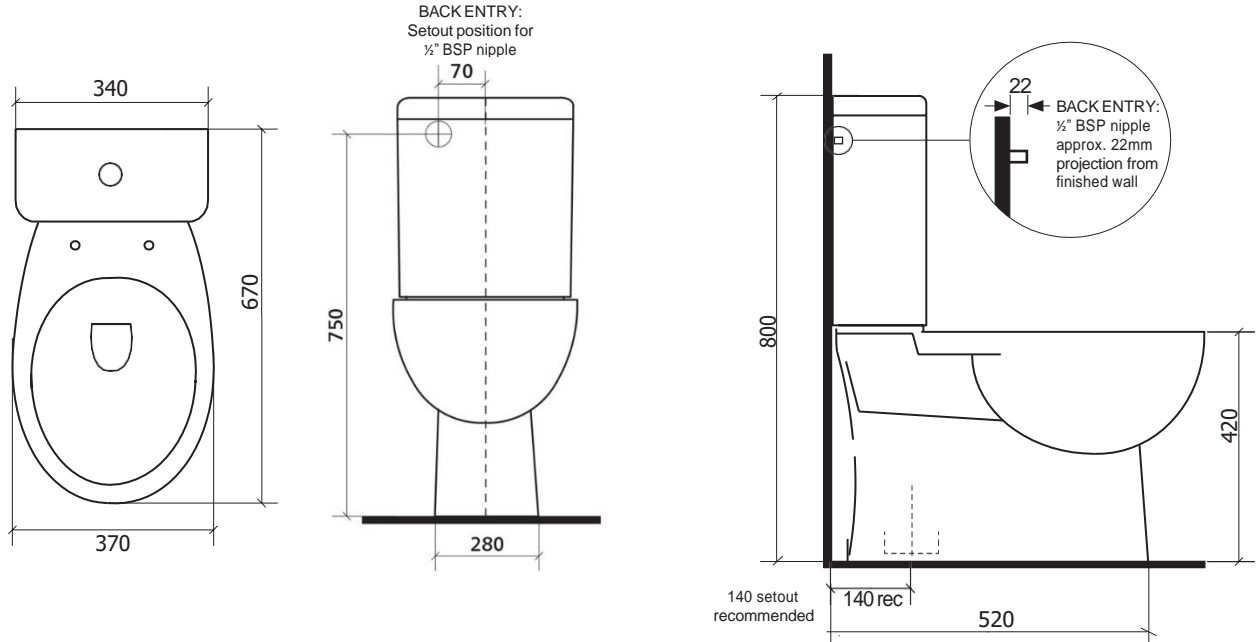

Rimless Clean Flush pan – for an efficient, powerful flush.

Easy care height – making it easier to get on and off the seat.

Please note:

- Installation shall be in accordance with AS/NZS3500.
- All measurements are in millimeters. Height dimensions are to base of pan. Make allowance for bedding.
- Bedding: Fix pan to floor using a sand cement mixture of 3:1 to a depth of 60mm. Do not use lime or fast-drying cement.
- Bracket fixing: The pan should be bedded with an acetic cured silicone sealant and fixed with the brackets supplied.
- Dimensions are nominal and subject to normal ceramic manufacturing variations.
- Specifications may vary without notice as part of our continuous improvement practices.
- Clean with a damp cloth. Do not use abrasive cleaners, liquids or pastes.



IMPORTANT

1. Inspect the components **before installation** to ensure there are no visible defects. If a defect is found, do not install the toilet suite and contact the supplier immediately. Claims for defects will not be accepted after the product has been installed.
2. This wall faced toilet suite is suitable for a variety of set-ups:
CISTERN — accommodates **Bottom Entry Inlet** connection (left or right stop valve) or Back Entry Inlet connection.
PAN — accommodates S-trap installation.
3. The toilet suite must be installed by a **licensed plumber**. Failure to do so may void the warranty.

CISTERN PACKAGE CONTENTS

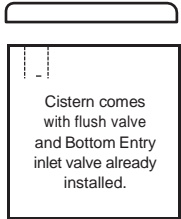

- 1 x ceramic cistern lid
- 1 x ceramic cistern base containing:
- 1 x flush valve
- 1 x bottom entry inlet valve

Cistern is supplied with flush valve and Bottom Entry inlet valve already installed. See Diagram A.

OPTIONAL EXTRA

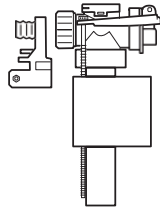

Optional with BE versions:
2 x back entry inlet valve Note: This component is only supplied with Back Entry version.

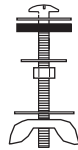

2 x bolts w seals
For attaching cistern to pan.



1 x plug
Only required if installing back entry (BE) version.



1 x rubber seal
For sealing outlet at base of cistern.

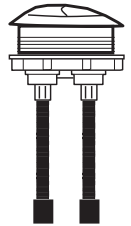

1 x flush button Half flush left, full flush right.

PAN PACKAGE CONTENTS

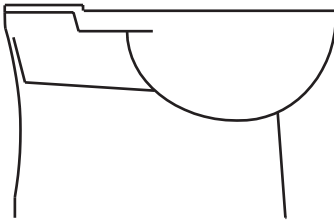

1 x ceramic pan

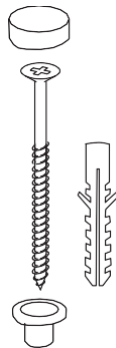

- 2 x caps (white)
- 2 x floor screws (+ white plugs)
- 2 x pan plugs (white)

Optional fixing #2 — used to secure pan to floor. Plastic plug is placed into hole at base of pan exterior; screw is rebated into plug. Cap is used to cover plastic plug.

SEAT PACKAGE CONTENTS

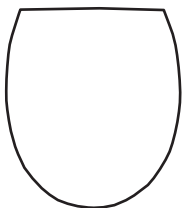

1 x seat and lid
Soft closing. Has receptor holes that slide onto pins on the pan.

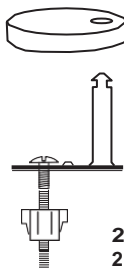

- 2 x white caps (used to cover stainless plate with pin)
- 2 x plates with pin (seat locates onto pins)
- 2 x bolts (used for securing plate and pin to pan)



1 S-TRAP PROCEDURE — SECURING THE PAN CONNECTOR IN PLACE

Determine the centre of the pan and mark the centre line on the floor and wall.

Work out the setout required. The recommended setout is 140mm. (Note: Additional setout can be achieved using a 20mm pan connector, not supplied.)

Position the pan connector into the floor outlet pipe (S-trap).

2 POSITIONING THE PAN

Use the centre line marked on the wall and floor to position the pan (see Step 1.1). Push the pan into the installed plastic pan connector. It is recommended that wedges are used to support the foot of the pan during positioning.

3 BOTTOM ENTRY INLET CONNECTION — SET-UP

SEE DIAGRAM A.

The bottom entry inlet valve is already installed on the right side of the cistern. The position can be swapped to the left side if required.

Connect the flexible inlet hose to the stop valve and water control inlet valve on the wall. Leave flexible inlet hose unsecured for now — for the bottom entry inlet connection, the flexible inlet hose will be connected to the cistern's inlet valve (see item 6 on next page).

4 OPTIONAL BACK ENTRY INLET CONNECTION — CISTERN SET-UP

(Note: The cistern comes supplied with the bottom entry inlet valve already installed and this needs to be removed.)

To set up the back entry connection, first remove the bottom entry inlet valve on the right side the cistern. DIAGRAM B STEP 1.

Use the plug supplied to securely fill the hole in the base of the cistern. DIAGRAM B STEP 2.

For ease of access while connecting the back entry inlet valve, temporarily remove the flush valve from the cistern. (You may need to rotate the base of the flush valve in order to position the overflow pipe towards the rear of the cistern. This will enable the cuff to be attached as required.)

Place the cuff of the back entry inlet valve onto the overflow pipe of the flush valve, and fully tighten the wing nut. DIAGRAM B STEP 3.

Re-fit the flush valve and back entry inlet valve to cistern.

Connect the flexible BE hose to the ½" BSP nipple. Run the flexible BE hose behind the flush valve, ensuring that the hose does not obstruct the operation of the flush valve. DIAGRAM C.

5 SECURING THE PAN ON THE FLOOR

Cement fixing (optional fixing #1)

If using cement bedding, level the pan while the cement mixture is workable. Fix pan to floor using a sand cement mixture of 3:1 to a depth of 60mm. Do not use lime or fast-drying cement.

Important: Allow at least 24 hours for the cement mixture to set before using the toilet.

Screw fixing (optional fixing #2)

Bed the pan with acetic cured silicone sealant, ensuring that the pan is level. Then place the pan plugs into the floor fixing holes in the pan and install the floor screws into place. The white caps can be used to cover the plugs on each side of the pan.

Important: Do not over-tighten the bolts or screws as this may cause the ceramic to crack and break.

DIAGRAM A

BOTTOM ENTRY SET-UP, AS SUPPLIED

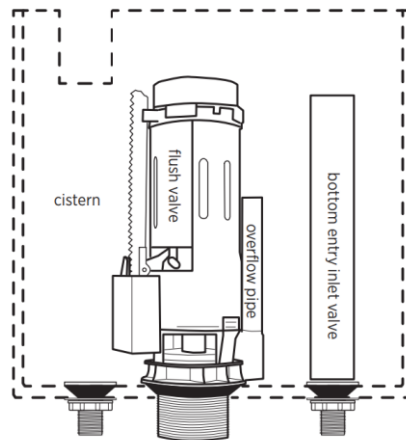

DIAGRAM B

INSTRUCTIONS TO CHANGE SET-UP FROM BOTTOM ENTRY TO BACK ENTRY

For back entry inlet, remove bottom entry inlet valve, plug hole, install back entry inlet valve.

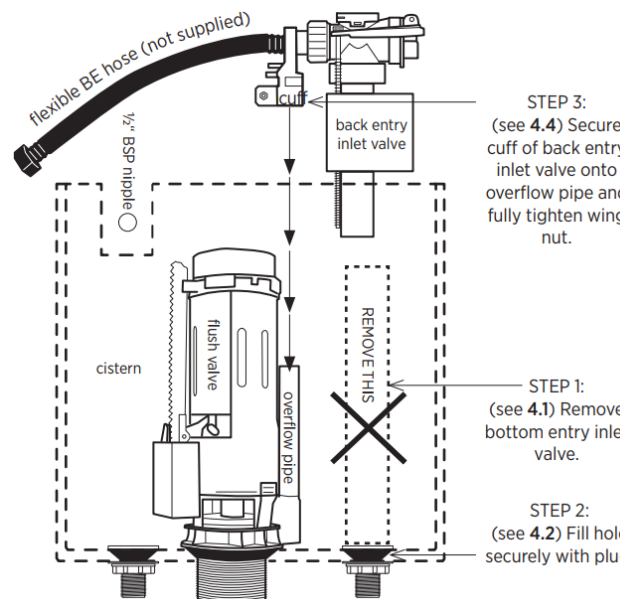
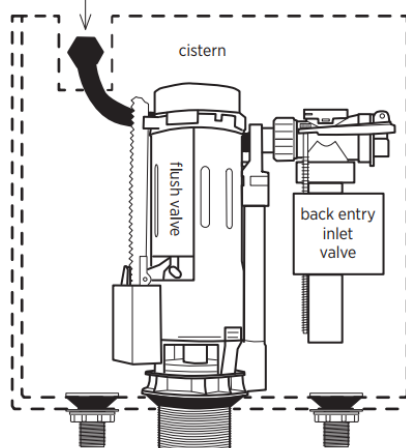

DIAGRAM C

COMPLETED BACK ENTRY SET-UP

(see 4.6) Attach flexible hose (not supplied) to ½" BSP nipple water inlet.



6 FIXING THE CISTERN TO THE PAN

First check the alignment of the cistern and pan attachment holes — place the cistern onto the pan and ensure that the holes align. Now remove the cistern.

Place the **rubber seal** onto the plastic pipe outlet at the base of the cistern and ensure it is securely attached. Locate the cistern outlet (with rubber seal) onto the pan, ensuring a good fit.

If using bottom entry inlet, connect the flexible inlet hose (see Step 3) to the cistern's water control valve on the base of the cistern. (Ignore this if using back entry connection.)

Now secure the cistern to the pan using **the two bolts with seals** in the cistern/pan attachment holes. SEE DIAGRAM D.

Flush the lines and connect the water supply and check the operation of the cistern.

7 FITTING THE CISTERN LID

Fit the flush button into the cistern lid, with the half flush on the left and full flush on the right. Ensure that the rubber feet of the flush button connect and line up correctly with the flush valve inside the cistern. Fit the cistern lid and push the buttons to check operation.

8 OPERATION AND MAINTENANCE

Press the half flush on the left side to save water and the full flush on the right as required. Clean the toilet with liquid detergent and a damp cloth.

Do not place water additives inside the cistern as this may have chemicals that damage the valves and impair the functionality of the cistern.

9 SEAT INSTALLATION INSTRUCTIONS

Secure the toggle bolts into the seat connection holes, ensuring that the pins line up with the receptor holes in the seat. Once correctly placed, ensure that the bolts are properly tightened.

Slide the white caps onto the plates with pins.

To fit the seat, slide it onto the pins. You may need to make adjustments to position the seat correctly.

To remove the seat, put seat in upright position to expose the seat release button at the base of the seat. To release, press button and lift the seat upwards to remove it.

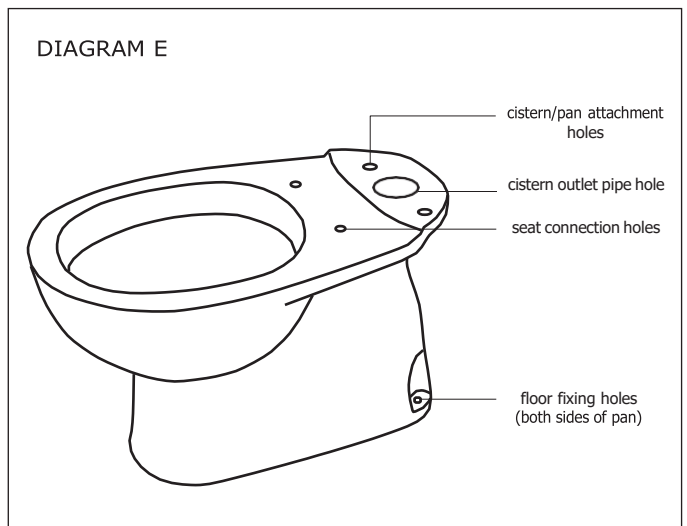
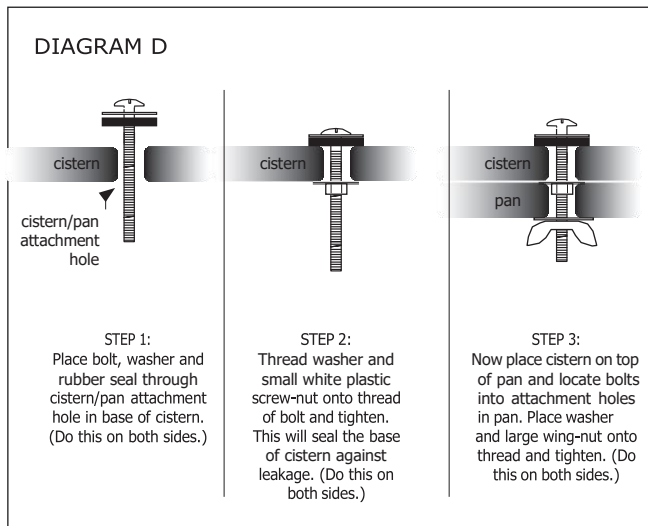
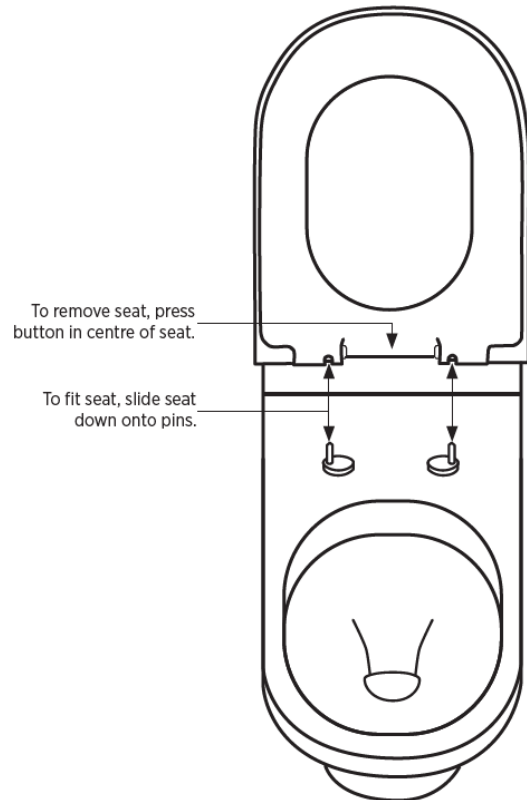

Please note:

- Installation shall be in accordance with AS/NZS3500.
- All measurements are in millimeters. Height dimensions are to base of pan. Make allowance for bedding.
- Bedding: Fix pan to floor using a sand cement mixture of 3:1 to a depth of 60mm. Do not use lime or fast-drying cement.
- Bracket fixing: The pan should be bedded with an acetic cured silicone sealant and fixed with the brackets supplied.
- Dimensions are nominal and subject to normal ceramic manufacturing variations.
- Specifications may vary without notice as part of our continuous improvement practices.
- Clean with a damp cloth. Do not use abrasive cleaners, liquids or pastes.